

SPECIFICATION SHEET

MODEL: UF-XL

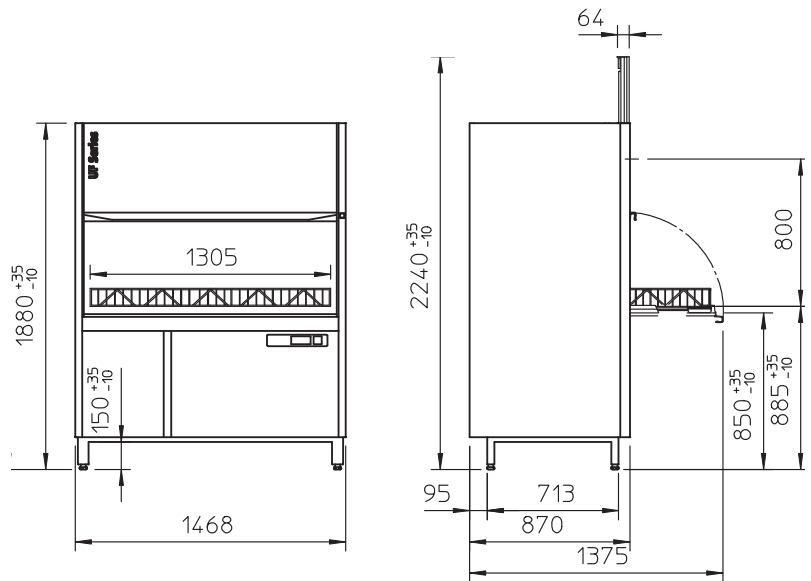

TECHNICAL INFORMATION

Dimensions	1468w x 870d x 1880h (2240h Door Open)
Rack Dimension	1305 X 672
Clear Entry Height	800
Rinse Water Consumption	7L Per Cycle

WATER CONNECTIONS

Connection Point	3/4 inch (19mm)
Inlet Temperature	60c Max
Flow Rate	4 L/Min
Flow Pressure	1.0 bar/Min

ELECTRICAL

3 Phase (Standard)	415v 3P 50Hz - 32amp (TCL 18.7Kw)
--------------------	-----------------------------------

GENERAL DATA

Weight (Net/Gross)	305/355Kg
Tank Capacity	138L
Noise Emission	70dB(A)
Cycle Times	1.5, 2.5 & 5 Minutes

STANDARD INCLUSIONS

1x 3phase Lead
1x 1m Flexible Water Connection Hose
1x 1m Flexible Waste Hose
1x 1308 x 672 Stainless Steel Rack

STANDARD FEATURES

- Touchscreen and colour- coded single-button control
- Quadruple wash water filtration
- Clouding sensor
- Active energy management
- Variopower washing pressure
- Fully insulated
- Drain pump
- Rinse booster pump
- Chemical pumps
- Optional drop down door